

Basic patterns
Gyptone ceilings
2.2.5 BIG Quattro 47 – Boards

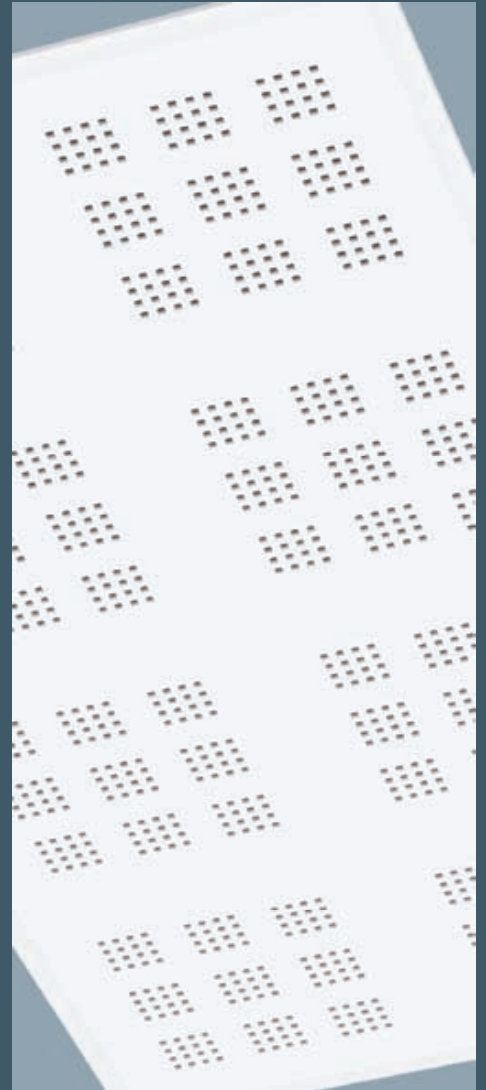

Gyptone®

Reflecting everyday life

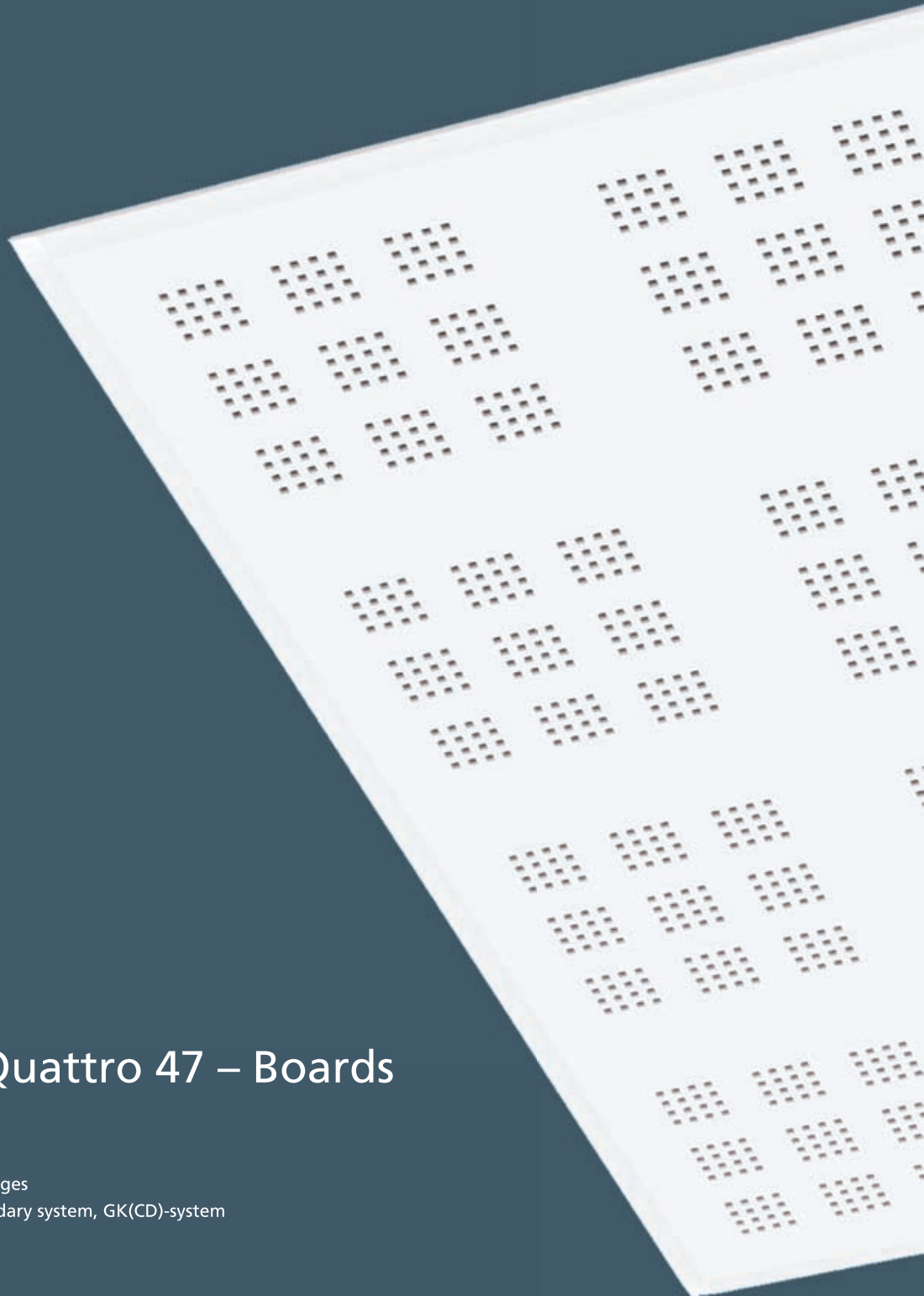

Gyptone BIG Quattro 47 – Boards

- Square holes
- Tapered filling edge on all four edges
- For timber battens, primary/secondary system, GK(CD)-system



Gyptone BIG Quattro 47

The product range for Gyptone BIG comprises two standard patterns with rectangular holes plus five standard patterns with square holes. The boards are made with tapered edges of type B1.

The big format makes it possible to create large ceiling surfaces without visible joints, also in combination with Gyptone BIG Base. The long slots or the square holes are the only thing that breaks the uniformity of the ceiling surface.

The boards have perforations which together with the acoustic backing tissue give good acoustic properties.

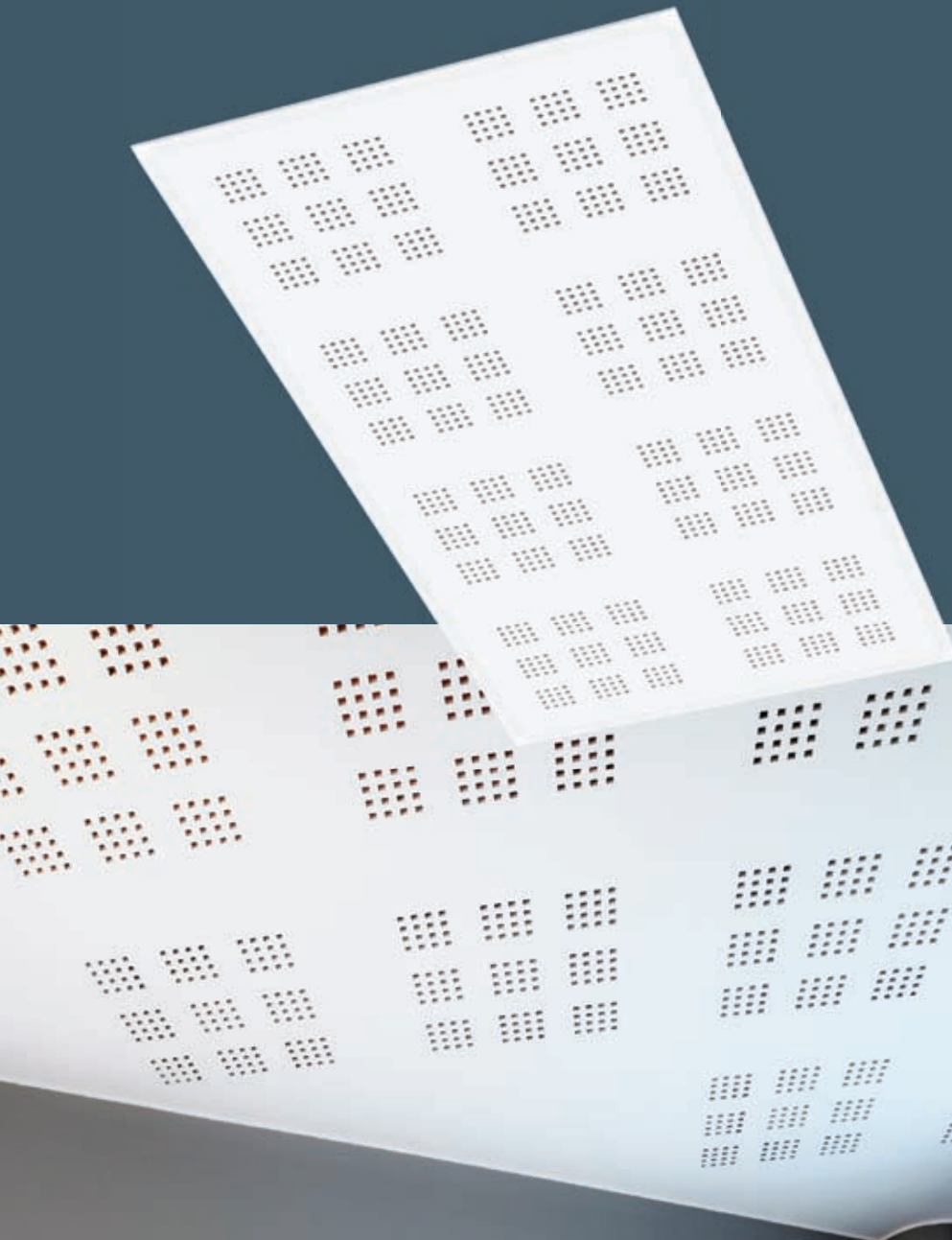

Acoustics

Practical absorption coefficient α_p

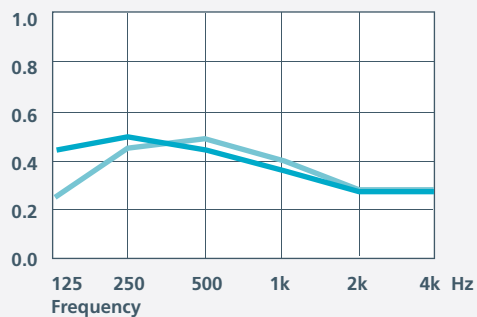





- 0.25 0.45 0.50 0.40 0.30 0.30
- 0.45 0.50 0.45 0.35 0.30 0.30
- Construction height 58 mm
- Construction height 200 mm

These measurements meet the requirements of ISO 354. All measurements were carried out on standard boards with acoustic tissue laminated on the back.

The construction height specifies the distance between the undersides of the suspended ceiling and the existing construction.

The board's sound absorption is affected by the construction height and by any mineral wool behind them.



Edges	Modular size (mm)	Thickness (mm)	Fixing systems			Fixing/Surface Treatment
B1 Long edge and short edge 	BIG Quattro 47: 1200 x 2400	12.5	Timber battens 	Primary/secondary system 	GK(CD)-system 	Not demountable/Unpainted

	<p>Gyptone inspection hatches are an integrated solution which suit all Gyptone BIG Line and Quattro patterns. This allows for easy access to installations behind them.</p> <p>Gyptone inspection hatch BIG 47 has a standard size: 350 x 350 mm</p>	<p>Tapered short and long edge</p> 
--	--	--

Hole size: 12 x 12 mm, cc 25 mm
Perforated area: 6%

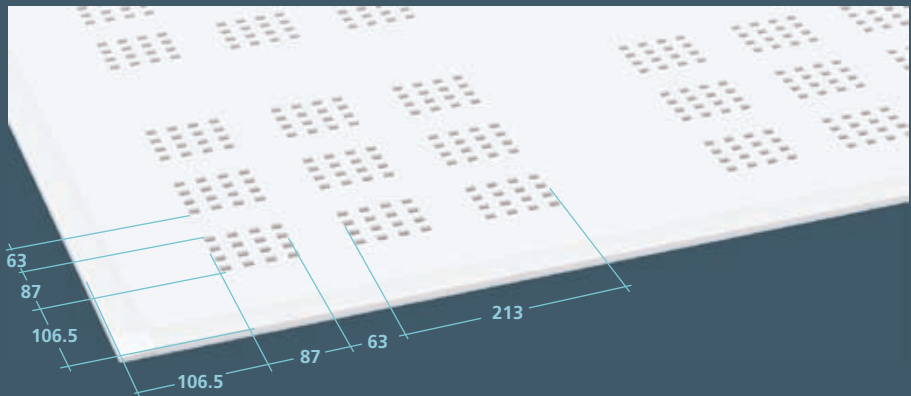

Design and technical data

Product description

Gyptone BIG is made out of Gyproc plasterboard. The holes are punched in the boards with great precision. The boards are backed with an acoustic tissue.

Fixing

Gyptone BIG is designed for direct or suspended screw-fixing and the boards are not demountable.

Construction height

The smallest possible standard construction height using the GK(CD) grid system in one level is 145 mm including the plasterboard.

Surface

Gyptone BIG is supplied unpainted. Painting is done on site after filling the joints.

The boards are painted using a roller. The boards must not be spray-painted, as this considerably reduces their sound absorption capacity.

Fire

A2-s1, d0.

Dimensional stability

Gyptone BIG should be installed and used in areas with a relative humidity not exceeding 70% for prolonged periods.

Dimensions

Modular size 1200 x 2400 mm.
Hole size 12 x 12 mm, cc 25 mm.

Weight

Approx. 8 kg/m².

Cleaning

Depends on the surface treatment.

Maintenance

Repainting must be done with a roller. The boards must not be spray-painted, as this impairs sound absorption.

More information can be found on www.gyptone.com





www.gyptone.com

Gyptone.com is not just a home page. Here you can find all Gyptone products "live" – see www.gyptone.com – choose the 3D product gallery and you will enter a 3D universe where all our products can be turned around and over, put together with different systems and displayed exactly the way you want them in your project.



Gyproc A/S
Hareskovvej 12
DK-4400 Kalundborg
Denmark
Tel.: +45 59 57 03 30
Fax: +45 59 57 03 01
e-mail: info@gyproc.com
www.gyptone.com

January 2007

